

AVTRON
ACCel500 COMMON BUS INVERTERS

(Frames FR4 to FR8)

AVTRON
ACCe1500 COMMON BUS INVERTERS

TABLE OF CONTENTS

<u>SECTION</u>		<u>PAGE</u>
I	SAFETY SUMMARY	1-1
1-1	Warnings	1-3
1-2	Safety Instructions	1-4
1-3	Earthing and Earth Fault Protection.....	1-4
1-4	Running the Motor.....	1-5
II	RECEIPT OF DELIVERY	2-1
2-1	Type Designation Code.....	2-1
2-2	Storage	2-2
2-3	Maintenance.....	2-2
2-4	Warranty	2-3
III	TECHNICAL DATA.....	3-1
3-1	Introduction.....	3-1
3-2	Power Ratings	3-2
3-2.1	Supply Voltage 480 VDC, Motor Voltage 380-500 VAC.....	3-2
3-2.2	Supply Voltage 575 VDC, Motor Voltage 525-690 VAC.....	3-4
3-3	Technical Information.....	3-5
IV	INSTALLATION	4-1
4-1	Mounting.....	4-1
4-2	Fan Cooling.....	4-7
4-2.1	Frames FR4 to FR8.....	4-7
4-2.2	Power Losses as Function of Switching Frequency	4-8
V	CABLING AND CONNECTIONS.....	5-1
5-1	Power Unit	5-1
5-1.1	Power Connections	5-2
5-1.1.1	DC Supply and Motor Cables.....	5-2
5-1.1.2	Control Cable.....	5-2
5-1.1.3	Fuses Used in ACCe1500 Inverter (480 VDC)	5-3
5-1.1.4	Fuses Used in ACCe1500 Inverter (575 VDC)	5-3
5-1.1.5	Cable Sizes for ACCe1500 Inverter (480 V).....	5-4
5-1.1.6	Cable Sizes for ACCe1500 Inverter (575 V).....	5-4

TABLE OF CONTENTS (continued)

<u>SECTION</u>		<u>PAGE</u>
5-1.2	Installation Instructions.....	5-5
5-1.2.1	Stripping Lengths of Motor and DC Supply Cables.....	5-6
5-1.2.2	ACCel500 Inverter Frames.....	5-7
5-1.3	Cable Installation and the UL Standards.....	5-9
5-1.4	Cable and Motor Insulation Checks.....	5-9
5-2	Control Unit.....	5-10
5-2.1	Control Connections.....	5-11
5-2.1.1	Control Cables.....	5-12
5-2.1.2	Galvanic Isolation Barriers.....	5-13
5-2.2	Control Terminal Signals.....	5-14
5-2.2.1	Digital Input Signal Inversions.....	5-15
5-2.2.2	Basic Board Jumper Selections (OPTA1).....	5-16
VI	COMMISSIONING.....	6-1
6-1	Safety.....	6-1
6-2	Commissioning the Inverter.....	6-1

AVTRON ACCe1500
COMMON BUS INVERTERS

SECTION I

SAFETY SUMMARY

W A R N I N G

Hazardous voltages are used in the operation of this equipment and may cause severe personal injury or the loss of life if proper precautions are not taken. The following precautions should be taken to reduce the risk of injury or death.

W A R N I N G

Separate motor overcurrent, overload, and overheating protection is required to be provided in accordance with the Canadian Electrical Code, Part I.

A V E R T I S S E M E N T

Le moteur doit être muni d'une protection distincte contre les surintensités, la surcharge et la surchauffe conformément au code canadien de l'électricité, première partie.

D A N G E R

Hazardous voltage will cause severe injury and death. Turn off and lock out all sources of power before servicing.

D A N G E R

Presence de tensions dangereuses pouvant entraîner la perte de vie. Couper l'alimentation avant le dépannage de cet équipement.

W A R N I N G

DO NOT OPERATE RADIO TRANSMITTERS or CELL PHONES IN THE VICINITY OF THE ACCel500 DRIVE. The ACCel500 Drive is an electronic device. Although it is designed to operate reliably in typical industrial environments, the ACCel500 Drive can be affected by radio and/or cell phone transmitters. It is possible to cause drive faults, inappropriate/unintended drive I/O activity, and unpredictable operation that could result in damage to the ACCel500 Drive, damage to other equipment, or serious injury to personnel.

Radio transmitter interference is a site specific phenomena. Generally, electrical wires connected to terminals on the ACCel500 Drive are the conduits for radio interference. Interference can be minimized by good wiring design and installation practice. It is recommended that signs be posted in and around the drive system, warning of the possibility of interference if the drive is in operation. DO NOT USE radio transmitters or cell phones in the area.

Absence of a radio interference problem is no guarantee that a problem will never occur as conditions and environments can change.

W A R N I N G

System Safety Considerations

In safety sensitive applications, it is strongly suggested that the system designer utilize a separate monitoring device to check the ACCel500 inputs and outputs, and other operating characteristics, to enhance the safety of personnel and property.

1. Only qualified personnel familiar with this equipment should be permitted to install, operate, troubleshoot, or repair the apparatus after reading and understanding this manual.
2. Installation of the equipment must be performed in accordance with the National Electrical Code and any other state or local codes. Proper grounding, conductor sizing, and short circuit protection must be installed for safe operation.

3. During normal operation, keep all covers in place and cabinet doors shut.
4. When performing hands-on inspections and maintenance, be sure the incoming AC feed is turned off and locked out. The ACCel500 Drive and motor may have hazardous voltages present even if the AC feed is turned off. ****NOTE**** The armature contactor does not remove hazardous voltages when opened.
5. When necessary to take measurements with the power turned on, do not touch any electrical connection points. Remove all jewelry from wrists and fingers. Make sure test equipment is in safe operating condition.
6. While servicing with the power on, stand on approved insulating material and be sure not to be grounded.
7. Follow the instructions in this manual carefully and observe all danger notices.

W A R N I N G

Accuracy of customer-installed calibration and configuration data is imperative in the operation of this equipment. Incorrect data may cause damage to the ACCel500 drive, motor, and process equipment.

W A R N I N G

Only a competent electrician may carry out the electrical installation.

1-1 WARNINGS

- The components of the power unit of the inverter are live when the ACCel500 inverter is connected to DC supply. Coming into contact with this voltage is extremely dangerous and may cause death or severe injury. The control unit is isolated from mains potential.
- The supply and motor terminals are live when the ACCel500 inverter is connected to DC supply, even if the motor is not running.

- The control I/O terminals are isolated from the mains potential. However, the relay outputs and other I/O terminals may have dangerous control voltage present even when the ACCel500 inverter is disconnected from the DC supply.
- The inverter has a large capacitive leakage current.
- If the inverter is used as a part of a machine, the machine manufacturer is responsible for providing the machine with a main switch (EN 60204-1).

1-2 SAFETY INSTRUCTIONS

- The ACCel500 inverter is meant for fixed installations only.
- Do not perform any measurements when the inverter is connected to the DC supply.
- After having disconnected the inverter from the DC supply, wait until the fan stops and the indicators on the keypad go out (if no keypad is attached see the indicator through the keypad base). Wait 5 more minutes before doing any work on ACCel500 inverter connections. Do not even open the cover before this time has expired.
- Do not perform any voltage withstand tests on any part of ACCel500 inverter. There is a certain procedure according to which the tests shall be performed. Ignoring this procedure may result in damaged product.
- Prior to measurements on the motor or the motor cable, disconnect the motor cable from the inverter.
- Do not touch the components on the circuit boards. Static voltage discharge may damage the components.
- Before connecting the inverter to DC supply, make sure that the ACCel500 inverter front and cable covers are closed.

1-3 EARTHING AND EARTH FAULT PROTECTION

The ACCel500 inverter must always be earthed with an earthing conductor connected to the earthing terminal. 

The earth fault protection inside the inverter only protects the inverter against earth faults in the motor or the motor cable.

Due to the high capacitive currents present in the inverter, fault current protective switches may not function properly. If fault current protective switches are used, they need to be tested with earth fault currents present during possible fault situations.

1-4 RUNNING THE MOTOR

MOTOR RUN CHECK LIST

1	Before starting the motor, check that the motor is mounted properly and ensure that the machine connected to the motor allows the motor to be started.
2	Set the maximum motor speed (frequency) according to the motor and the machine connected to it.
3	Before reversing the motor, make sure that this can be done safely.
4	Make sure that no power correction capacitors are connected to the motor cable.
5	Make sure that the motor terminals are not connected to mains potential.

SECTION II

RECEIPT OF DELIVERY

ACCel500 inverters have undergone scrupulous tests and quality checks at the factory before they are delivered to the customer. However, after unpacking the product, check that no signs of transportation damage is to be found on the product and that the delivery is complete (compare the type designation of the product to the code below, see Figure 2-1).

Should the drive have been damaged during shipping, please contact primarily the cargo insurance company or the carrier.

If the delivery does not correspond to your order, contact the supplier immediately.

2-1 TYPE DESIGNATION CODE

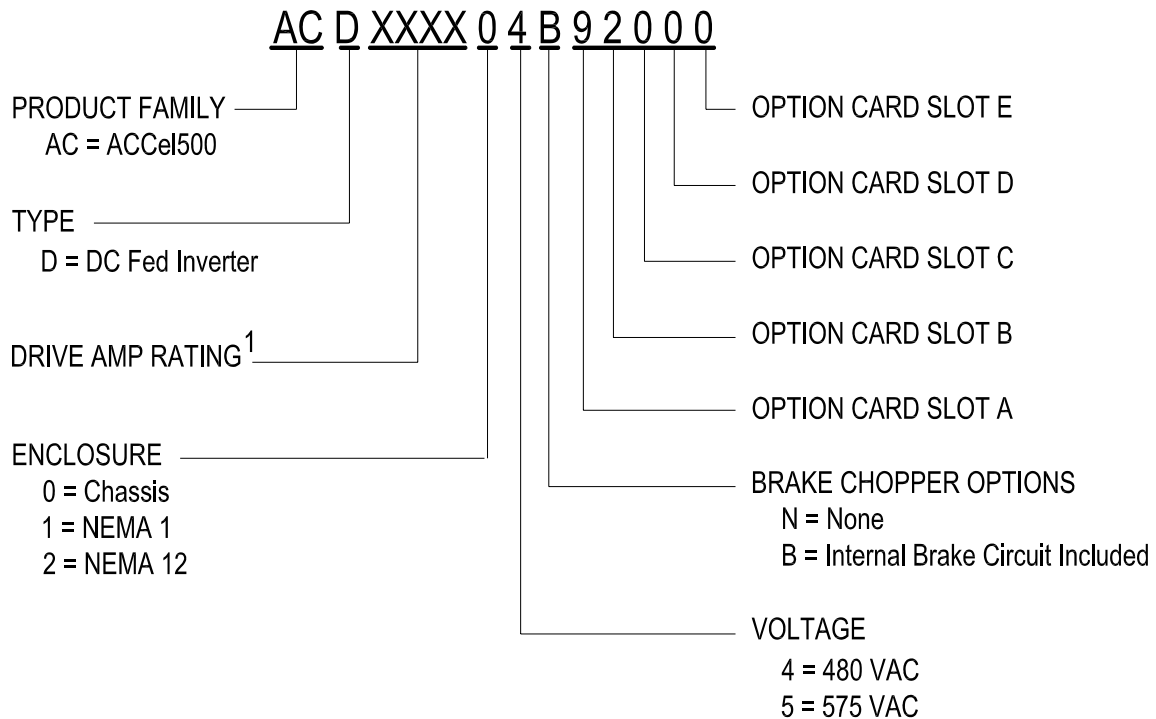

¹For amp rating, 0007 = 7 A, 0022 = 22 A, 0205 = 205 A, etc.

Figure 2-1. ACCel500 Inverter Type Designation Code, FR4 to FR8

The standard features of ACCel500 inverters are listed in Table 2-1.

TABLE 2-1. ACCEL500 INVERTERS STANDARD FEATURES

Standard features FR4, FR6 and FR7	DC connection
	NEMA 1 or NEMA 2 (IP21)
	Air cooling
	Integrated charging
	Alphanumeric control panel (in the front of the module)
	I/O modules A1 & A2
	Standard board
	Safety CE / UL
Standard features FR8	DC connection
	Chassis (IP00)
	Air cooling
	Integrated charging
	Alphanumeric control panel (in the front of the module)
	I/O modules A1 & A2
	Standard board
	Safety CE / UL

2-2 STORAGE

If the inverter is to be stored before use, make sure that the ambient conditions are acceptable:

- Storage temperature –40 to +70°C
- Relative humidity < 95%, no condensation

If the inverter is stored for over 12 months, contact service before connecting the inverter to the power supply.

2-3 MAINTENANCE

In normal conditions, ACCel500 inverters are maintenance-free. However, we recommend to clean the heatsink with compressed air whenever necessary. The cooling fan can easily be changed if necessary.

It may also be necessary to check the tightening torques of terminals at certain intervals.

2-4 WARRANTY

Only manufacturing defects are covered by the warranty. The manufacturer assumes no responsibility for damages caused during or resulting from transport, receipt of the delivery, installation, commissioning or use.

The manufacturer shall in no event and under no circumstances be held responsible for damages and failures resulting from misuse, wrong installation, unacceptable ambient temperature, dust, corrosive substances or operation outside the rated specifications.

Neither can the manufacturer be held responsible for consequential damages.

The Manufacturer's warranty period is 18 months from the delivery or 12 months from the commissioning whichever expires first (General delivery terms NL92/Orgalime S92).

The local distributor may grant a warranty time different from the above. This warranty time shall be specified in the distributor's sales and warranty terms. assumes no responsibility for any other warranties than that granted by itself.

In all matters concerning the warranty, please contact your distributor first.

SECTION III

TECHNICAL DATA

3-1 INTRODUCTION

The figure below presents the block diagram of the ACCel500 inverter. Mechanically, the inverter consists of two units, the Power Unit and the Control Unit.

The Power Unit contains an inverter bridge which consists of IGBT switches and produces a symmetrical, 3-phase PWM-modulated AC voltage to the motor. To protect the DC link capacitors, the Power Unit also contains a charging circuit for controlled DC link charge. Use the B+ and DC- terminals in order to bypass the charging circuit.

The Motor and Application Control Block is based on microprocessor software. The microprocessor controls the motor based on the information it receives through measurements, parameter settings, control I/O and control keypad. The motor and application control block controls the motor control ASIC which, in turn, calculates the IGBT positions. Gate drivers amplify these signals for driving the IGBT inverter bridge.

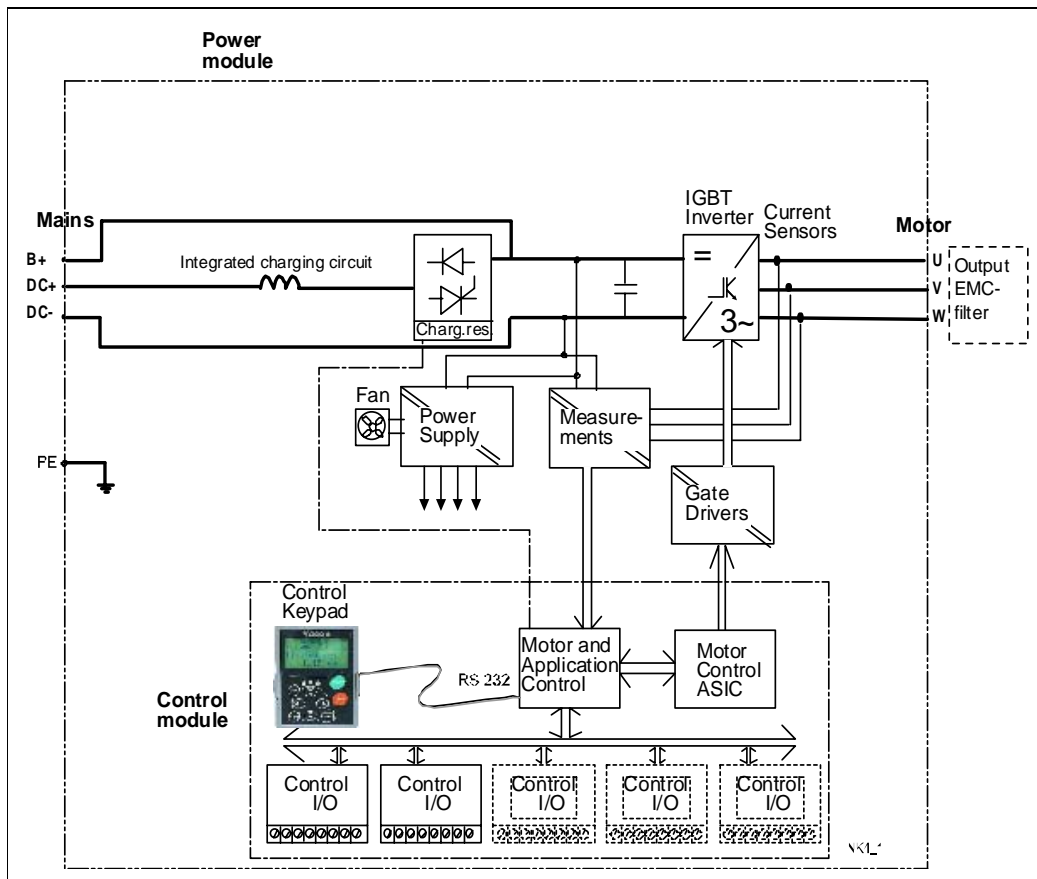

Figure 3-1. ACCel500 Inverter Block Diagram

The control keypad constitutes a link between the user and the inverter. The control keypad is used for parameter setting, reading status data and giving control commands. It is detachable and can be operated externally and is connected via a cable to the inverter. Instead of the control keypad, a PC can be used to control the inverter if connected through a similar cable.

The basic control interface and the parameters are easy to use. If a more versatile interface or parameters are required, a more suitable application can be chosen. See the ACCel500 Adjustable Frequency Drives Application manual for more information on the different applications.

Optional I/O expander boards that increase the number of inputs and outputs to be used are also available. For more information, contact the manufacturer or your local distributor.

3-2 POWER RATINGS

3-2.1 SUPPLY VOLTAGE 480 VDC, MOTOR VOLTAGE 380-500 VAC

High overload = Max current IS, 2 sec/20 sec, 150% overloadability, 1 min/10 min
Following continuous operation at rated output current, 150% rated output current (IH) for 1 min, followed by a period of load current less than rated current, and of such duration that the RMS output current, over the duty cycle, does not exceed rated output current (IH)

Low overload = Max current IS, 2 sec/20 sec, 110% overloadability, 1 min/10 min
Following continuous operation at rated output current, 110% rated output current (IL) for 1 min, followed by a period of load current less than rated current, and of such duration that the RMS output current, over the duty cycle, does not exceed rated output current (IL)

Frames FR4 to 7 are available as NEMA 1 or NEMA 2 (IP21) and FR8 as chassis-mounted (IP 00).

TABLE 3-1. POWER RATINGS AND DIMENSIONS
ACCEL500 INVERTER,
SUPPLY VOLTAGE 480 VDC

Motor Voltage 380-500 VAC, 50/60 Hz, 3~											
Inverter Type	Loadability					Motor Shaft Power				Frame	Dimensions and Weight in/lb (mm/kg)
	Low		High			513 VDC Supply		675 VDC Supply			
	Rated Continuous Current I _L (A)	10% Overload Current (A)	Rated Continuous Current I _H (A)	50% Overload Current (A)	Max Current I _S	10% Overload 40°C P(kW)	50% Overload 50°C P(kW)	10% Overload 40°C P(kW)	50% Overload 50°C P(kW)		
ACD0003	4.3	4.7	3.3	5	6.2	1.5	1.1	2.2	1.5	FR4	5.03X11.5X7.48/11 (128x292x190/5)
ACD0007	9	9.9	7.6	11.4	14	4	3	5.5	4	FR4	
ADC0009	12	13.2	9	13.5	18	5.5	4	7.5	5.5	FR4	
ACD0012	16	17.6	12	18	24	7.5	5.5	11	7.5	FR6	7.68X20.4X9.33/35 (195x519x237/16)
ACD0016	23	25.3	16	24	32	11	7.5	15	11	FR6	
ACD0022	31	34	23	35	46	15	11	18.5	15	FR6	
ACD0031	38	42	31	47	62	18.5	15	22	18.5	FR6	
ACD0038	46	51	38	57	76	22	18.5	30	22	FR6	
ACD0045	61	67	46	69	92	30	22	37	30	FR7	
ACD0061	72	79	61	92	122	37	30	45	37	FR7	9.33X23.3X10.1/64 (237x591x257/29)
ACD0072	87	96	72	108	144	45	37	55	45	FR7	
ACD0087	105	116	87	131	174	55	45	75	55	FR7	
ACD0105	140	154	105	158	210	75	55	90	75	FR8	11.2X28.4X11.3/106 (285X721X288/48)

NOTE: The rated currents in given ambient temperatures are achieved only when the switching frequency is equal to or less than the factory default.

3-2.2 SUPPLY VOLTAGE 575 VDC, MOTOR VOLTAGE 525-690 VAC

High overload = Max current IS, 2 sec/20 sec, 150% overloadability, 1 min/10 min
 Following continuous operation at rated output current, 150 % rated output current (IH) for 1 min, followed by a period of load current less than rated current, and of such duration that the RMS output current, over the duty cycle, does not exceed rated output current (IH)

Low overload = Max current IS, 2 sec/20 sec, 110% overloadability, 1 min/10 min
 Following continuous operation at rated output current, 110% rated output current (IL) for 1 min, followed by a period of load current less than rated current, and of such duration that the RMS output current, over the duty cycle, does not exceed rated output current (IL)

Frames FR4 to 7 are available as IP21 and FR8 as IP 00

TABLE 3-2. POWER RATINGS AND DIMENSIONS
 ACCeL500 INVERTER,
 SUPPLY VOLTAGE 575 VDC

Motor Voltage 525-690 VAC, 50/60 Hz, 3~									
Inverter Type	Loadability					Motor Shaft Power		Frame	Dimensions and Weight WxHxD/kg
	Low		High			930 VDC Supply			
	Rated Continuous Current I _L (A)	10% Overload Current (A)	Rated Continuous Current I _H (A)	50% Overload Current (A)	Max Current I _S	10% Overload 40°C P(kW)	50% Overload 50°C P(kW)		
ACD0004	4.5	5	3.2	5	6.7	3	2.2	FR6	7.68x20.4x9.33/35 (195x519x237/16)
ACD0005	5.5	6.1	4.5	6.8	9	4	3		
ACD0007	7.5	8.3	5.5	8.3	11	5.5	4		
ACD0010	10	11	7.5	11.3	15	7.5	5.5		
ACD0013	13.5	14.9	10	15	20	11	7.5		
ACD0018	18	19.8	13.5	20.3	27	15	11		
ACD0022	22	24.2	18	27	36	18.5	15		
ACD0027	27	29.7	22	33	44	22	18.5		
ACD0034	34	37	27	41	54	30	22		
ACD0041	41	45	34	51	68	37.5	30	FR7	9.33x23.3x10.1/64 (237x591x257/29)
ACD0052	52	57	41	62	82	45	37.5		
ACD0062	62	68	52	78	104	55	45	FR8	11.2x28.4x11.3/106 (285x721x288/48)
ACD0080	80	88	62	93	124	75	55		
ACD0100	100	110	80	120	160	90	75		

NOTE: The rated currents in given ambient temperatures are achieved only when the switching frequency is equal to or less than the factory default.

3-3 TECHNICAL INFORMATION

TABLE 3-3. TECHNICAL INFORMATION

DC Connection	Input Voltage U_{in}	480 VDC; 575 VDC; -0% to +0% , the ripple voltage of the inverter supply voltage generated during the rectification of the fundamental frequency AC voltage must be less than 50Vp-p.
	Connection to DC supply	Once per minute or less (normal)
	Starting delay	FR4 to FR8: 2 s
Motor Connection	Output voltage	$3 \sim 0 - U_{in} / 1.4$
	Continuous output current	I_H : Ambient temperature max. +50°C, overload 1.5 x I_H (1 min./10 min.) I_L : Ambient temperature max. +40°C, overload 1.1 x I_L (1 min./10 min.)
	Starting torque	I_S for two seconds, depends on the motor
	Starting current	I_S for 2 s every 20 s
	Output frequency	0 to 320 Hz; 7200 Hz (special use)
	Frequency resolution	Depends on application
Control Characteristics	Control method	Frequency control U/f Open Loop Sensorless Vector Control Closed Loop Frequency Control Closed Loop Vector Control
	Switching frequency (see parameter 2.6.9)	480 VAC: 1 to 16 kHz; Factory default 10 kHz ACD0072 and greater: 1 to 10 kHz; Factory default 3.6 kHz 575 VAC: 1 to 6 kHz; Factory default 1.5 kHz
	Frequency reference	Resolution 0.1% (10-bit), accuracy ±1%
	Analog input	Resolution 0.01 Hz
	Panel reference	Resolution 0.01 Hz
	Field weakening point	30 to 320 Hz
	Acceleration time	0 to 3000 sec
Deceleration time	0 to 3000 sec	
Ambient Conditions	Ambient operating temperature	-10°C (no frost)...+50°C: I_H (FR10: max. +40°C) -10°C (no frost)...+40°C: I_L
	Storage temperature	-40°C to +70°C
	Relative humidity	0 to 95% RH, non-condensing, non-corrosive, no dripping water
	Air quality: chemical vapors mechanical particles	IEC 721-3-3, unit in operation, class 3C2 IEC 721-3-3, unit in operation, class 3S2
	Altitude	100% load capacity (no derating) up to 1,000 m 1-% derating for each 100m above 1000.; max. 3000m
	Vibration EN50178/EN60068-2-6	5 to 150 Hz Displacement amplitude 1 mm (peak) at 5 to 15.8 Hz Max acceleration amplitude 1 G at 15.8 to 150 Hz
	Shock EN50178, EN60068-2-27	UPS Drop Test (for applicable UPS weights) Storage and shipping: max. 15 G, 11 ms (in package)
	Enclosure class	FR4 to 7 IP21/NEMA1 standard FR8 IP 00 standard
EMC (at default settings)	Immunity	Fulfils all EMC standards

TABLE 3-3. TECHNICAL INFORMATION (continued)

Safety		EN 50178 (1997), EN 60204-1 (1996), EN 60950 (2000, 3rd edition) (as relevant), CE, UL, CUL, FI, GOST R, IEC 61800-5; (see unit nameplate for more detailed approvals)
Control Connections	Analog input voltage	0...+10V, $R_i = 200\text{ k}\Omega$, (-10V to +10V joystick control) Resolution 0.1%, accuracy $\pm 1\%$
	Analog input current	0(4)...20 mA, $R_i = 250\ \Omega$ differential
	Digital inputs (6)	Positive or negative logic; 18 to 30 VDC
	Auxiliary voltage	+24V, $\pm 15\%$, max. 250mA
	Output reference voltage	+10V, +3%, max. load 10mA
	Analog output	0(4) to 20mA; RL max. 500 Ω ; Resolution 10bit; Accuracy $\pm 2\%$
	Digital outputs	Open collector output, 50mA/48V
	Relay outputs	2 programmable change-over relay outputs Switching capacity 24VDC/8A, 250VAC/8A, 125VDC/0.4A Min. switching load: 5V/10mA
Protections	Overvoltage trip limit	480VDC: 911VDC; 575 VDC: 1200VDC
	Undervoltage trip limit	480 VDC: 333VDC; 575 VDC: 460 VDC
	Earth fault protection	In case of earth fault in motor or motor cable, only the inverter is protected
	Output phase supervision	Trips if any of the output phases is missing
	Overcurrent protection	Yes
	Unit overtemperature protection	Yes
	Motor overload protection	Yes
	Motor stall protection	Yes
	Motor underload protection	Yes
	Short-circuit protection of +24V and +10V reference voltages	Yes

TABLE 3-4. ACCel500 INVERTER DC CURRENTS, SUPPLY VOLTAGE 480 VDC

Structure	I_{nom} (output)	Motor cos	I_{dc} (input)
FR4	4.3	0.79	4.4
	9	0.82	9.6
	12	0.83	1.0
FR6	16	0.84	17.5
	22	0.85	24.4
	31	0.85	34.3
	38	0.86	43
	45	0.86	50
FR7	61	0.86	68
	72	0.87	82
	87	0.87	99
	105	0.87	119
FR8	140	0.88	160

TABLE 3-5. ACCel500 INVERTER DC CURRENTS,
SUPPLY VOLTAGE 575 VDC

Structure	I _{nom} (output)	Motor cos	Idc (input)
FR6	4.5	0.81	4.7
	5.5	0.82	5.9
	7.5	0.83	8.1
	10.0	0.84	10.9
	13.5	0.85	14.9
	18.0	0.85	19.9
	22.0	0.86	24.6
	27.0	0.86	30.2
	34.0	0.86	38.1
FR7	41.0	0.87	46
	52.0	0.87	59
FR8	62.0	0.87	70
	80.0	0.88	92
	100.0	0.88	115

TABLE 3-6. DC LINK CAPACITANCE BY STRUCTURE

Structure	X _{xxx} / μF	X _{xxx} / μF
FR4 0003-0007	165	
FR4 0009-0012	235	
FR6	1000	500
FR7	1650	900
FR8	3300	1800

SECTION IV

INSTALLATION

4-1 MOUNTING

The inverter can be mounted in either a vertical or horizontal position on a wall or on the back plane of a cubicle. Enough space must be reserved around the inverter to ensure sufficient cooling, see Figure 4-6. You must follow the minimum dimensions for installation, see Table 4-6 and Table 4-7. Also make sure that the mounting plane is relatively even.

The inverter is fixed with four screws (or bolts, depending on the unit size). The dimensions for installation are presented in Figure 4-6 and Table 4-6.

Lift units bigger than FR7 out of the package using a jib crane. Ask the factory or your local distributor for information on how to lift the unit safely.

The following pages show the dimensions for ACCel500 inverter with a default enclosure in Figure 4-1, and with flange mounting in Figure 4-2 and Figure 4-4. Dimensions for the opening needed in flange mounting are given in Table 4-3 and Table 4-5.

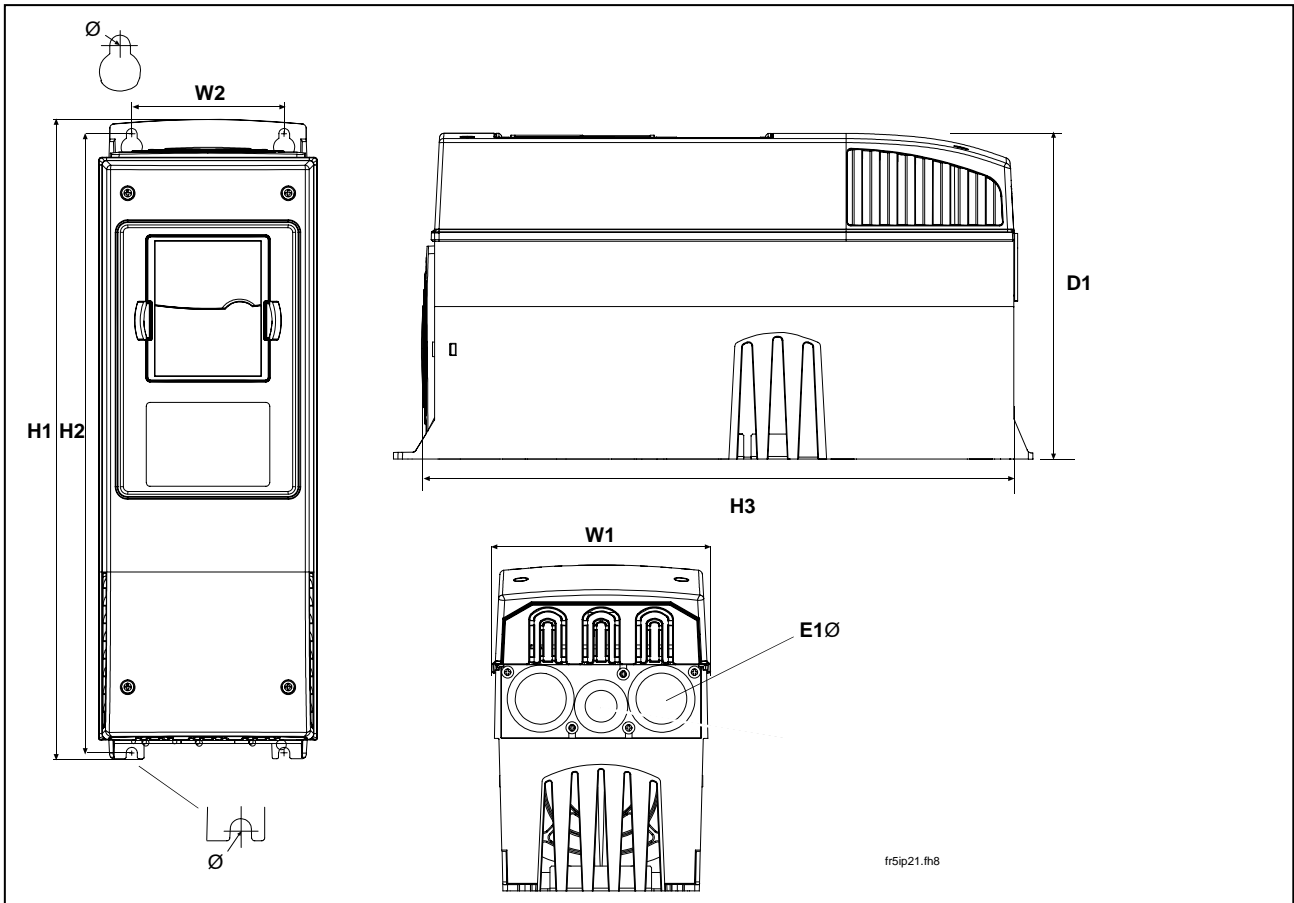

Figure 4-1. ACCel500 Inverter Dimensions, IP21

TABLE 4-1. DIMENSIONS FOR DIFFERENT INVERTER TYPES, IP21

Type	Dimensions [in (mm)]							
	W1	W2	H1	H2	H3	D1	Ø	E1Ø
ACD0004 to 0012	5.03 (128)	3.94 (100)	12.9 (327)	12.3 (313)	11.5 (292)	7.48 (190)	0.27 (7)	3 x 1.11 (3 x 28.3)
ACD0016 to 0045 ACD0004 to 0034	7.68 (195)	5.83 (148)	22.0 (558)	21.3 (541)	20.4 (519)	9.33 (237)	0.35 (9)	3 x 1.46 (3 x 37)
ACD0061 to 0105 ACD0041 to 0052	9.33 (237)	7.48 (190)	24.8 (630)	24.2 (614)	23.3 (591)	10.1 (257)	0.35 (9)	3 x 1.85 (3 x 47)
ACD0140 ACD0062 to 0100	11.2 (285)	10.0 (255)	29.7 (755)	28.8 (732)	28.4 (721)	12.3 (312)	0.35 (9)	3 x 2.32 (3 x 59)

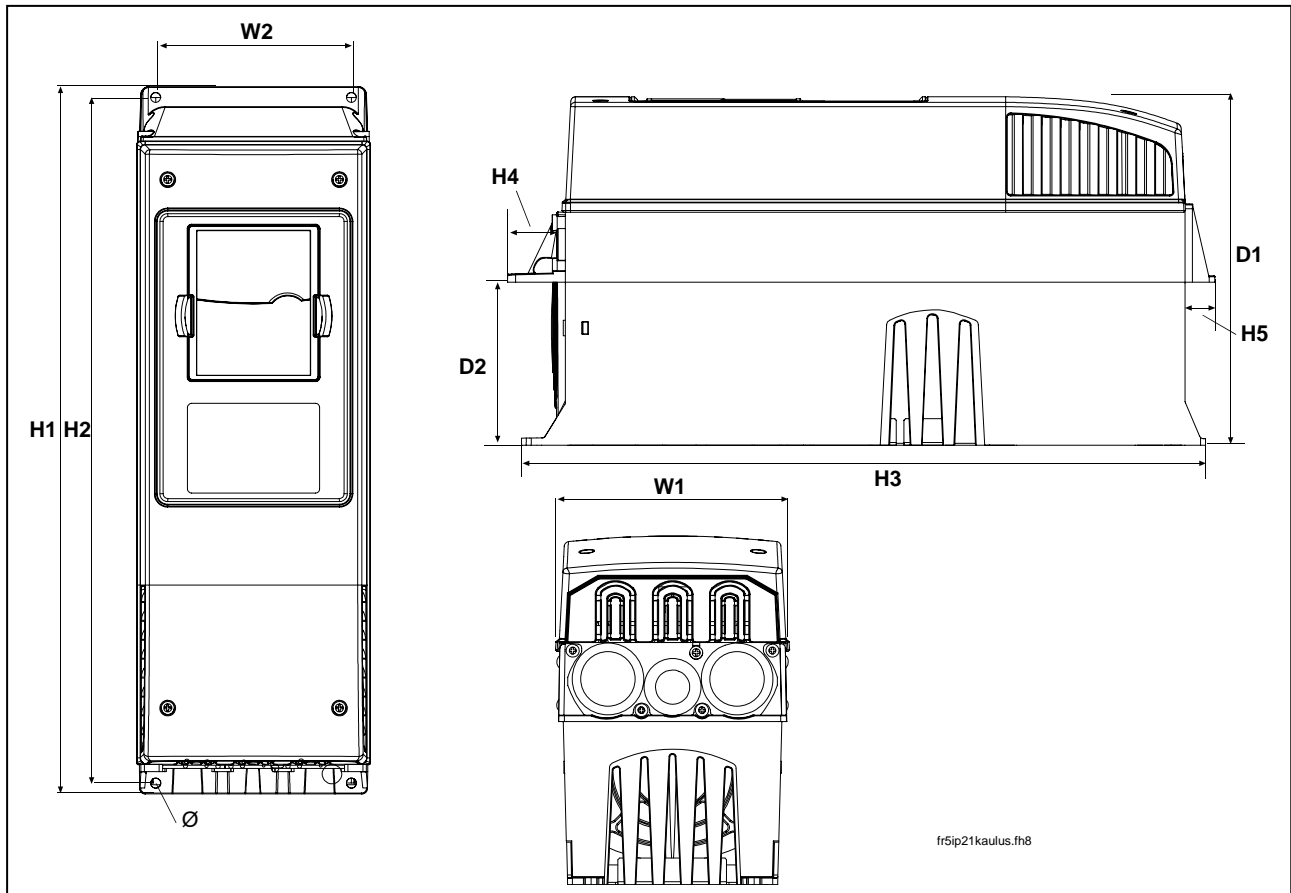

Figure 4-2. ACCel500 Inverter Dimensions, IP21 with Flange, FR4 and FR6

TABLE 4-2. DIMENSIONS FOR INVERTER TYPES FR4 AND FR6, IP21 WITH FLANGE

Type	Dimensions [in (mm)]									
	W1	W2	H1	H2	H3	H4	H5	D1	D2	Ø
ACD0004 to 0012	5.03 (128)	4.45 (113)	13.3 (337)	12.8 (325)	12.9 (327)	1.18 (30)	0.87 (22)	7.48 (190)	3.03 (77)	0.27 (7)
ACD0016 to 0045	7.68 (195)	6.69 (170)	22.0 (560)	21.6 (549)	22.0 (558)	1.18 (30)	0.79 (20)	9.33 (237)	4.17 (106)	0.26 (6.5)

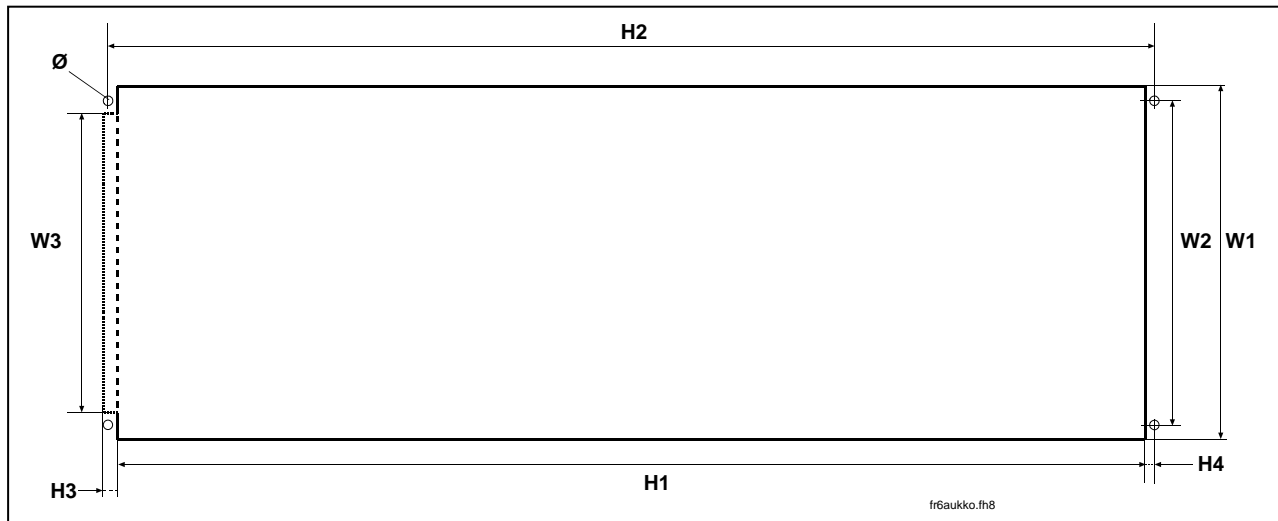

Figure 4-3. The Opening Needed for Flange Mounting, FR4 and FR6

TABLE 4-3. OPENING DIMENSIONS FOR FLANGE MOUNTING, FR4 AND FR6

Type	Dimensions [in (mm)]							
	W1	W2	W3	H1	H2	H3	H4	Ø
ACD0004—0012	4.84 (123)	4.45 (113)	—	12.4 (315)	12.8 (325)	—	0.20 (50)	0.26 (50)
ACD0016—0045 ACD0004—0034	7.28 (185)	6.69 (170)	6.18 (157)	21.2 (539)	21.6 (549)	0.27 (7)	0.20 (50)	0.26 (50)

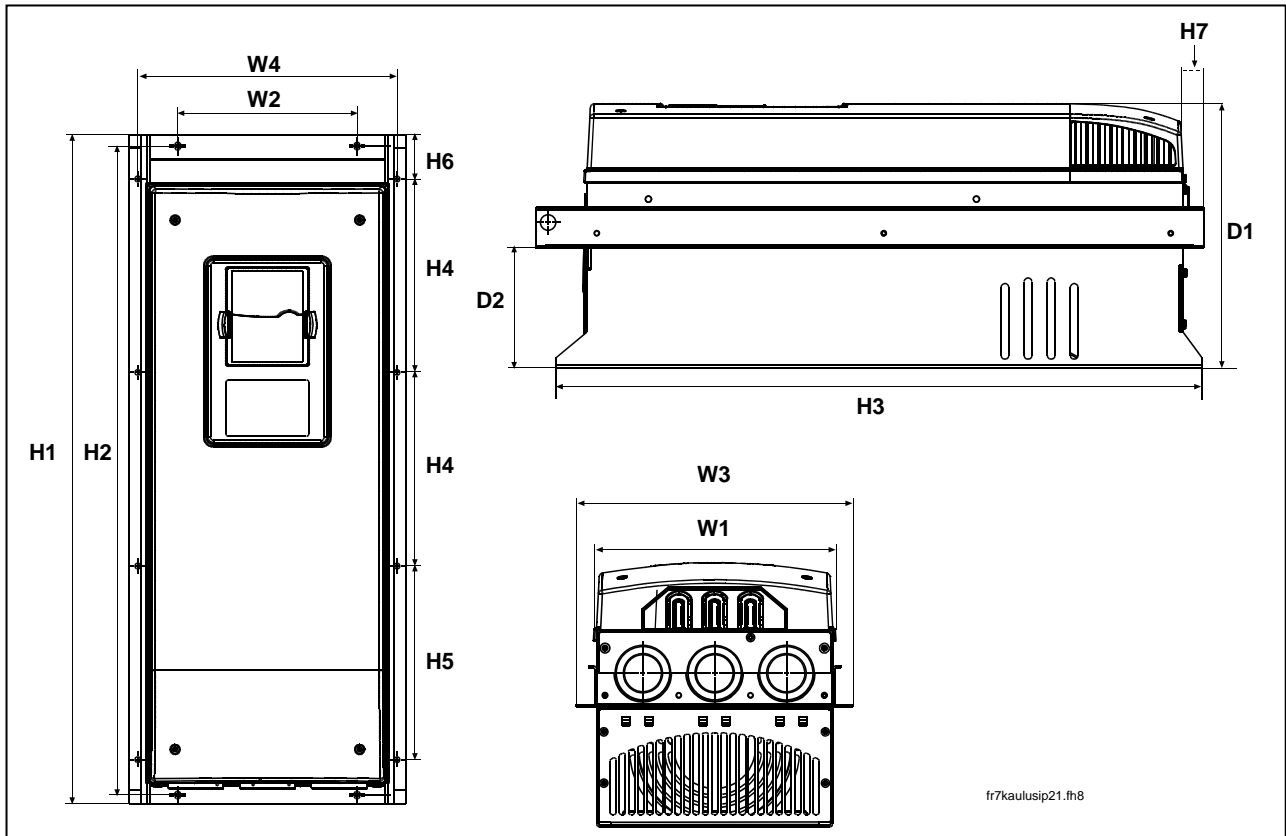

Figure 4-4. ACCEL500 Inverter Dimensions, IP21 with Flange, FR4 and FR6

TABLE 4-4. DIMENSIONS FOR INVERTER TYPES FR7 AND FR8, IP21 WITH FLANGE

Type	Dimensions [in (mm)]													
	W1	W2	W3	W4	H1	H2	H3	H4	H5	H6	H7	D1	D2	Ø
ACD0061—0105	9.33	6.89	10.6	3.96	25.7	24.3	24.8	7.42	7.42	0.91	0.79	10.12	4.61	0.22
ACD0041—0052	(237)	(175)	(270)	(253)	(652)	(632)	(630)	(188.5)	(188.5)	(23)	(20)	(257)	(117)	(5.5)
ACD0062—0100	11.2	—	13.0	13.0	29.7	—	29.3	10.2	10.4	1.69	1.24	11.34	4.33	0.35
ACD0140	(285)		(355)	(330)	(755)		(745)	(258)	(265)	(43)	(57)	(288)	(110)	(9)

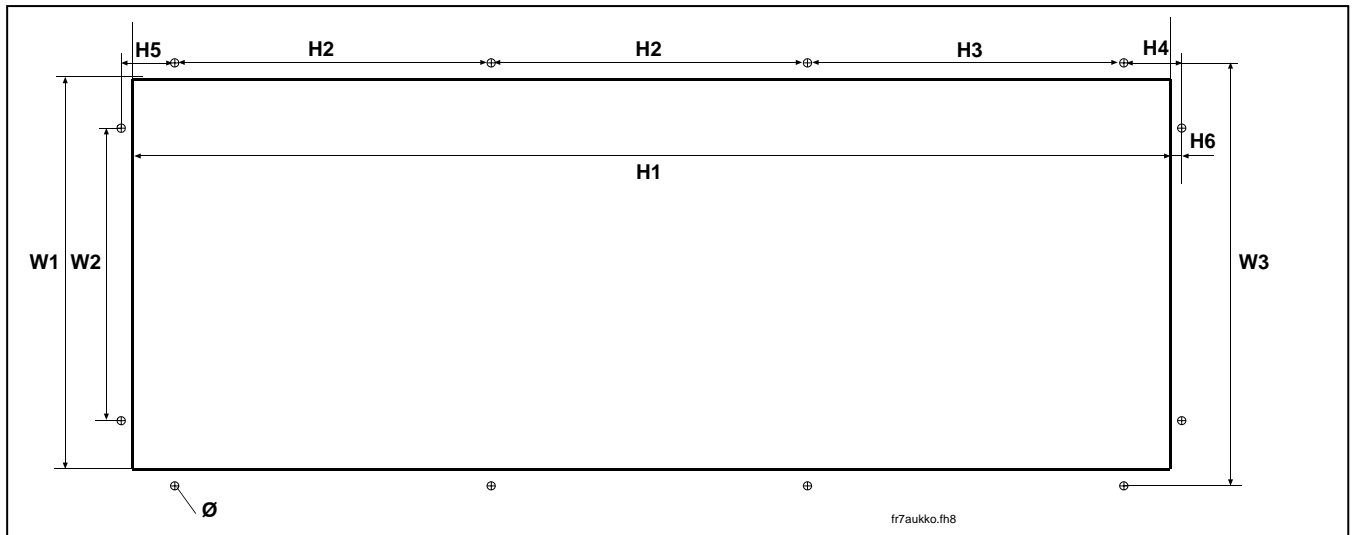

Figure 4-5. The Opening Needed for Flange Mounting, FR7/FR8

TABLE 4-5. OPENING DIMENSIONS FOR FLANGE MOUNTING, FR7/FR8

Type	Dimensions [in (mm)]									
	W1	W2	W3	H1	H2	H3	H4	H5	H6	Ø
ACD50061 to 0105 ACD0041 to 0052	9.17 (233)	6.89 (175)	3.96 (253)	24.4 (619)	7.42 (188.5)	7.42 (188.5)	1.36 (34.5)	1.26 (32)	0.27 (7)	0.22 (5.5)
ACD0140 ACD0062 to 0100	11.9 (301)	–	13.0 (330)	31.9 (810)	10.2 (258)	10.4 (265)	–	–	–	3.04 (9)

4-2 FAN COOLING

4-2.1 FRAMES FR4 TO FR8

Enough free space must be left around the inverter to ensure sufficient air circulation and cooling. You will find the required dimensions for free space in the table below.

If several units are mounted on top of each other, the required free space equals C + D (see figure below). Moreover, the outlet air used for cooling by the lower unit must be directed away from the air intake of the upper unit. When planning the cooling for the space, take into consideration that the inverter's heat loss is 2.5% of the nominal capacity.

TABLE 4-6. MOUNTING SPACE DIMENSIONS

Type	Dimensions [in (mm)]				
	A	A ₂	B	C	D
ACD0004 to 0012	0.79 (20)		0.79 (20)	3.94 (100)	1.97 (50)
ACD0016 to 0048 ACD0004 to 0034	1.18 (30)		0.79 (20)	6.30 (160)	3.15 (80)
ACD0061 to 0105 ACD0041 to 0052	3.15 (80)		3.15 (80)	11.8 (300)	3.94 (100)
ACD0062 to 0100 ACD01405	3.15 (80)	5.91 (150)	3.15 (80)	11.8 (300)	7.87 (200)

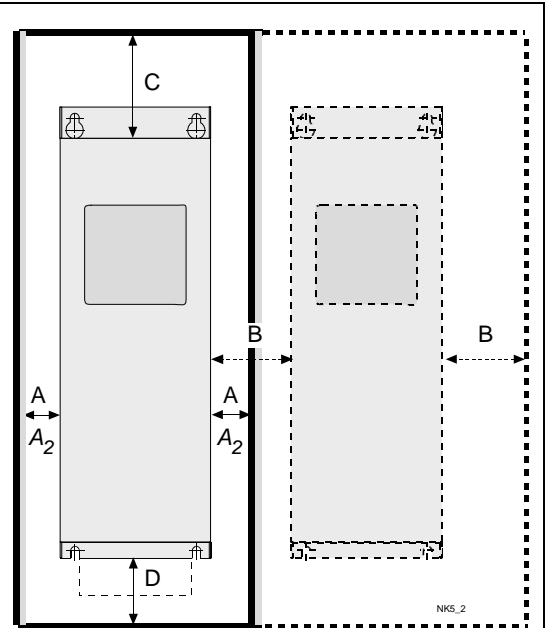

- A** = clearance around the inverter (see also **A₂** and **B**)
- A₂** = clearance needed on either side of the inverter for fan change (without disconnecting the motor cables)
- ** = min. clearance for fan change
- B** = distance from one inverter to another or distance to cabinet wall
- C** = free space above the inverter
- D** = free space underneath the inverter

TABLE 4-7. REQUIRED COOLING AIR

Type	Greatest possible heat loss (kW)	Cooling air required [cfm/h (m ³ /h)]
ACD0004—0012	0.2	41 (70)
ACD0016—0048 ACD0004—0034	1 0.75	250 (425)
ACD0061—0105 ACD0041—0052	1.9 1.2	250 (425)
ACD0062—0100 ACD01405	3.3 2.25	382 (650)

4-2.2 POWER LOSSES AS FUNCTION OF SWITCHING FREQUENCY

Raising the switching frequency of the drive, to reduce motor noise, for example, inevitably affects the power losses and cooling requirements as shown in the figure below. It illustrates the power loss FR7 as function of switching frequency. For more information, contact the manufacturer or your local distributor.

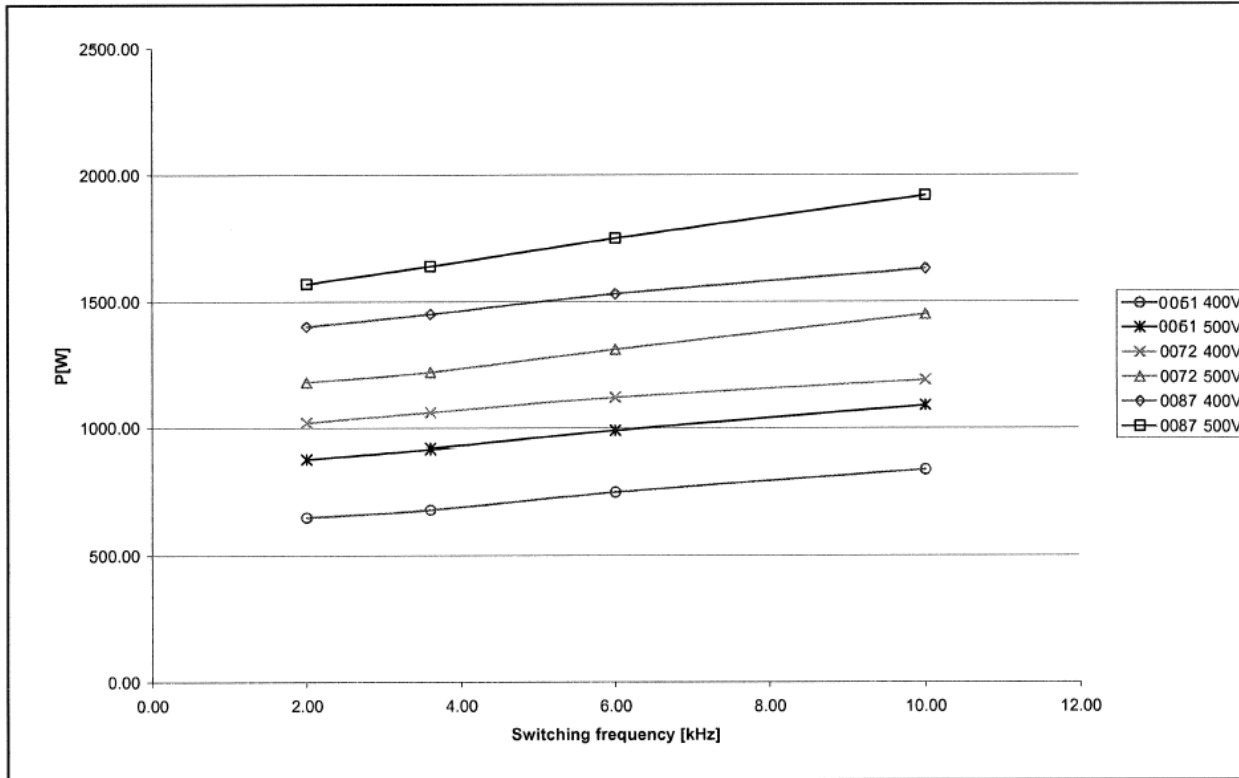

Figure 4-6. Power Loss as a Function of Switching Frequency; 0061 to 0087

SECTION V

CABLING AND CONNECTIONS

5-1 POWER UNIT

The following wiring diagrams show the supply and motor connections.

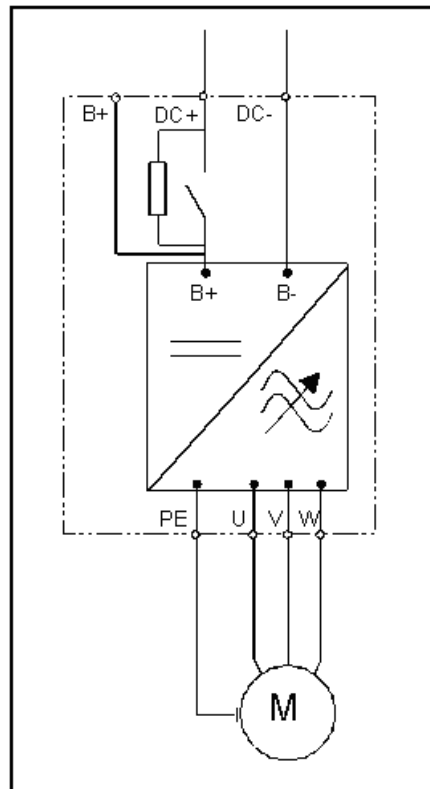

Figure 5-1. The Basic Wiring Diagram

5-1-1 POWER CONNECTIONS

5-1.1.1 DC Supply and Motor Cables

The power cables are connected to terminals DC+ and DC- (R+/B+ and DC terminals when using an external charging circuit) and the motor cables to terminals U, V, and W. A cable entry gland should be used at the motor cable end to reach the EMC levels, see Table 5-1.

Use cables with a heat resistance of at least +60°C. The cables and the fuses must be sized according to the inverter nominal output current which you can find on the rating plate. Installation of cables according to UL regulations is presented in section 6.1.3 and aR fuse sizes in Tables 5-2 and 5-3. The minimum dimensions of the Cu-cables are shown in Table 5-4.

If the motor temperature protection of the drive is used as an overload protection, the cable shall be chosen accordingly. If three or more cables are used in parallel for bigger units, each cable requires a separate overload protection.

These instructions apply only to installations with one motor and one cable connection from the inverter to the motor. In any other case, ask the factory for more information.

TABLE 5-1. CABLE TYPES REQUIRED TO MEET STANDARDS

Cable Type	Level T
Supply cable	Power cable intended for fixed installation and the specific DC voltage. Shielded cable not required.
Motor cable	Power cable equipped with concentric protection wire and intended for the specific mains voltage
Control cable	Screened cable equipped with compact low-impedance shield.

5-1.1.2 Control Cable

For information on control cables, see section 5-2.1.1 and Table 5-1.

5-1.1.3 Fuses Used in ACCel500 Inverter (480 VDC)

TABLE 5-2. FUSES USED IN ACCel500 INVERTER (480 VDC)

Frame	Type	IL [A]	Bussman aR Fuse Type	Fuse Size	Fuse Un [V]	Fuse In [A]	No. of Fuses
FR4	ACD0004	4.3	170M1560	000	690	20	2
FR4	ACD0009	9	170M1565	000	690	63	2
FR4	ACD0012	12	170M1565	000	690	63	2
FR6	ACD0016	16	170M1565	000	690	63	2
FR6	ACD0022	22	170M1565	000	690	63	2
FR6	ACD0031	31	170M1565	000	690	63	2
FR6	ACD0038	38	170M1567	000	690	100	2
FR6	ACD0045	45	170M1567	000	690	100	2
FR7	ACD0061	61	170M1568	000	690	125	2
FR7	ACD0072	72	170M1570	000	690	200	2
FR7	ACD0087	87	170M1570	000	690	200	2
FR7	ACD0105	105	170M1571	000	690	250	2
FR8	ACD0140	140	170M3819	1	690	400	2

5-1.1.4 Fuses Used in ACCel500 Inverter (575 VDC)

TABLE 5-3. FUSES USED IN ACCel500 INVERTER (575 VDC)

Frame	Type	IL [A]	Bussman aR fuse type	Fuse size	Fuse Un [V]	Fuse In [A]	No. of fuses
FR6	ACD0004	4.5	170M2673	00	1000	20	2
FR6	ACD0005	5.5	170M2673	00	1000	20	2
FR6	ACD0007	7.5	170M2673	00	1000	20	2
FR6	ACD0010	10	170M2673	00	1000	20	2
FR6	ACD0013	13.5	170M2679	00	1000	63	2
FR6	ACD0018	18	170M2679	00	1000	63	2
FR6	ACD0022	22	170M2679	00	1000	63	2
FR6	ACD0027	27	170M2679	00	1000	63	2
FR6	ACD0034	34	170M2683	00	1000	160	2
FR7	ACD0041	41	170M2683	00	1000	160	2
FR7	ACD0052	52	170M2683	00	1000	160	2
FR8	ACD0062	62	170M4200	1SHT	1250	350	2
FR8	ACD0080	80	170M4200	1SHT	1250	350	2
FR8	ACD0100	100	170M4200	1SHT	1250	350	2

Information About Fuses

aR fuses protect the cables of the device against short circuits.

gR fuses are designed to protect the device against both overcurrent and short circuits.

gG fuses are generally used to protect cables against overcurrent and short circuits.

5-1.1.5 Cable Sizes for ACCel500 Inverter (460 V)

TABLE 5-4. CABLE SIZES FOR ACCel500 INVERTER (460 V)

Frame	Type	IL [A]	Supply cable Cu [AWG (mm ²)]	Motor cable Cu [AWG (mm ²)]	Terminal cable size	
					Main terminal [AWG (mm ²)]	Earth terminal [AWG (mm ²)]
FR4	ACD0004 to 0009	3 - 9	2*16 (2*1.5)	3*16+16 (3*1.5+1.5)	18 - 12 (1 to 4)	18 - 14 (1 to 2.5)
	ACD0012	12	2*14 (2*2.5)	3*14+14 (3*2.5+2.5)	18 - 12 (1 to 4)	18 - 14 (1 to 2.5)
FR6	ACD0016 to 0045	16 - 45	2*8 (2*10)	3*8+8 (3*10+10)	14 - 1/0 Cu (2.5 to 50 Cu) 10 - 1/0 Al (6 to 50 Al)	12 - 2 (2.5 to 35)
FR7	ACD0061	61	2*6 (2*16)	3*6+6 (3*16+16)	13 - 0 Cu (2.5 to 50 Cu) 9 - 0Al (6 to 50 Al)	12 - 2 (2.5 to 35)
	ACD0072	72	2*4 (2*25)	3*4+6 (3*25+16)	14 - 1/0 Cu (2.5 to 50 Cu) 10 - 1/0Al (6 to 50 Al)	10 - 2/0 (6 to 70)
	ACD0087	(87	2*2 (2*35)	3*2+6 (3*35+16)	14 - 1/0 Cu (2.5 to 50 Cu) 10 - 1/0Al (6 to 50 Al)	10 - 2/0 (6 to 70)
	ACD0105	105	2*1/0 (2*50)	3*1/0+4 (3*50+25)	14 - 1/0 Cu (2.5 to 50 Cu) 10 - 1/0Al (6 to 50 Al)	10 - 2/0 (6 to 70)
FR8	ACD0140	140	2*2/0 (2*70)	3*2/0+2 (3*70+35)	4 - 3/0 Cu/Al (25 to 95 Cu/Al)	4 - 3/0 (25 to 95)

5-1.1.6 Cable Sizes for ACCel500 Inverter (575 V)

TABLE 5-5. CABLE SIZES FOR ACCel500 INVERTER (575 V)

Frame	Type	IL [A]	Supply cable Cu [AWG (mm ²)]	Motor cable Cu [AWG (mm ²)]	Terminal cable size	
					Main terminal [AWG (mm ²)]	Earth terminal [AWG (mm ²)]
FR6	ACD0004 to 0007	3 to 7	2*14 (2*2.5)	3*14+14 (3*2.5+2.5)	14 – 1/0 (2.5 to 50 Cu) 10 – 1/0 (6 to 50 Al)	14 – 2 (2.5 to 35)
	ACD0010 to 0013	10-13	2*14 (2*2.5)	3*14+14 (3*2.5+2.5)	14 – 1/0 (2.5 to 50 Cu) 10 – 1/0 (6 to 50 Al)	14 – 2 (2.5 to 35)
	ACD0018	18	2*12 (2*4)	3*12+12 (3*4+4)	14 – 1/0 (2.5 to 50 Cu) 10 – 1/0 (6 to 50 Al)	14 – 2 (2.5 to 35)
	ACD0022	22	2*10 (2*6)	3*10+10 (3*6+6)	14 – 1/0 (2.5 to 50 Cu) 10 – 1/0 (6 to 50 Al)	14 – 2 (2.5 to 35)
	ACD0027 to 0034	27-34	2*8 (2*10)	3*8+8 (3*10+10)	14 – 1/0 (2.5 to 50 Cu) 10 – 1/0 (6 to 50 Al)	14 – 2 (2.5 to 35)
FR7	ACD0041	41	2*8 (2*10)	3*8+8 (3*10+10)	14 – 1/0 (2.5 to 50 Cu) 10 – 1/0 (6 to 50 Al)	10 – 1/0 (6 to 50)
	ACD0052	52	2*6 (2*16)	3*6+6 (3*16+16)	14 – 1/0 (2.5 to 50 Cu) 10 – 1/0 (6 to 50 Al)	10 – 1/0 (6 to 50)
FR8	ACD0062 to 0080	62–80	2*4 (2*25)	3*4+6 (3*25+16)	4 – 3/0 (25 to 95 Cu/Al)	4 – 3/0 (25 to 95)
	ACD0100	100	2*2 (2*35)	3*2+6 (3*35+16)		

5-1.2 INSTALLATION INSTRUCTIONS

1	Before starting the installation, check that none of the components of the inverter are live.						
2	If the inverter is installed outside the cubicle, cabinet or device space, you need to install a separate inverter cover (see, for example, Figure 5-3) in accordance with protection class IP21 requirements. There is no need to install the inverter cover if the inverter is installed in a cubicle, separate cabinet or device space.						
3	<p>Place the motor cables sufficiently far from other cables:</p> <ul style="list-style-type: none"> • Avoid placing the motor cables in long parallel lines with other cables • If the motor cables runs in parallel with other cables, note the minimum distances between the motor cables and other cables given in the table below. • The given distances also apply between the motor cables and signal cables of other systems. • The maximum length of the motor cables is 300 m (units with power greater than 1.5 kW) and 100 m (units with power from 0.75 to 1.5 kW). • The motor cables should cross other cables at an angle of 90 degrees. <table border="1" style="margin-left: auto; margin-right: auto;"> <thead> <tr> <th style="text-align: center;">Distance between Cables [in (m)]</th> <th style="text-align: center;">Shielded Cable [in (m)]</th> </tr> </thead> <tbody> <tr> <td style="text-align: center;">11.8 (0.3)</td> <td style="text-align: center;">≤1.97 (≤50)</td> </tr> <tr> <td style="text-align: center;">39.4 (1.0)</td> <td style="text-align: center;">≤ 7.87 (≤200)</td> </tr> </tbody> </table>	Distance between Cables [in (m)]	Shielded Cable [in (m)]	11.8 (0.3)	≤1.97 (≤50)	39.4 (1.0)	≤ 7.87 (≤200)
Distance between Cables [in (m)]	Shielded Cable [in (m)]						
11.8 (0.3)	≤1.97 (≤50)						
39.4 (1.0)	≤ 7.87 (≤200)						
4	If cable insulation checks are needed, see section 5-1.4.						
5	<p>Connect the cables:</p> <ul style="list-style-type: none"> • Strip the motor and DC supply cables as advised in Figure 5-2 and Table 5-6. • Remove the screws of the cable protection plate. Do not open the cover of the power unit. • Make holes into and pass the cables through the rubber grommets on the bottom of the power unit. The rubber grommets are delivered in a separate bag. • Connect the DC supply, motor and control cables into their respective terminals. • For information on the installation of greater units, please contact the factory or your local distributor. • For Information on cable installation according to UL regulations, see section 5-1.3. • For information on cable installation according to EMC regulations, see section 5-1.3. • Make sure that the control cable wires do not come in contact with the electronic components of the unit. • If an external brake resistor (optional) is used, connect its cable to the appropriate terminal. • Check the connection of the earth cable to the motor and the inverter terminals marked with . • Connect the separate shield of the power cable to the earth terminals of the inverter, motor and the supply centre. • Attach the cable protection plate with the screws. • Ensure that the control cables or the cables of the unit are not trapped between the frame and the protection plate. 						

5-1.2.1 Stripping Lengths of Motor and DC Supply Cables

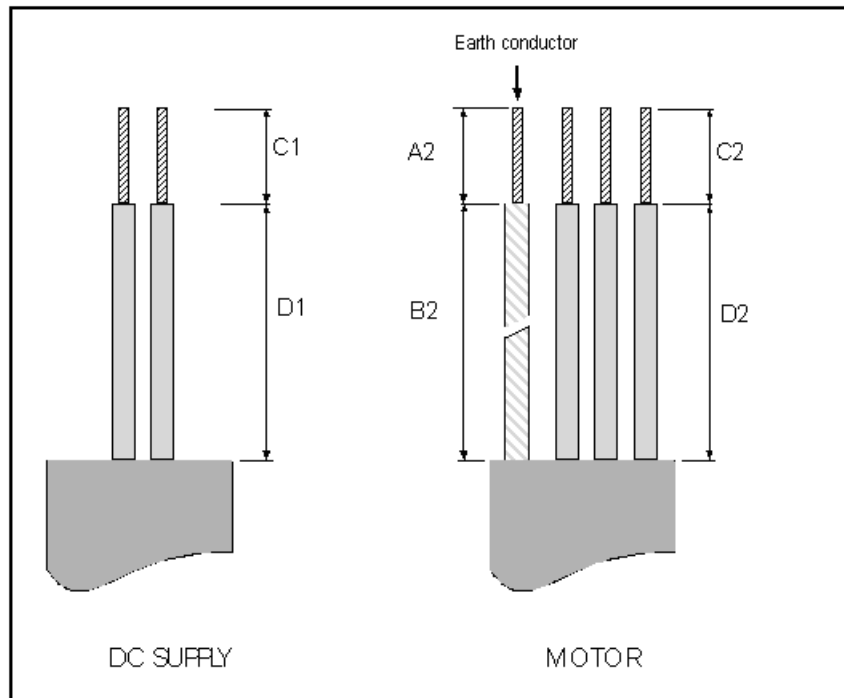

Figure 5-2. Stripping of Cables

TABLE 5-6. CABLE STRIPPING LENGTHS [in (mm)]

Frame size	C1	D1	A2	B2	C2	D2
FR4	.039 (10)	0.79/2.76 (20/70)	0.28 (7)	1.97 (50)	0.28 (7)	1.38 (35)
FR6	0.59 (15)	2.36/3.15 (60/80)	0.79 (20)	3.54 (90)	0.59 (15)	2.36 (60)
FR7	0.98 (25)	4.72/5.51 (120/140)	0.98 (25)	4.72 (120)	0.98 (25)	4.72 (120)
FR8 0140	1.18 (30)	5.91 (150)	0.91 (23)	9.45 (240)	0.91 (23)	9.45 (240)

5-1.2.2 ACCel500 Inverter Frames



Figure 5-3. ACCel500 Inverter, FR4



Figure 5-4. ACCel500 Inverter, FR6, Protection Class IP21



Figure 5-5. ACCel500 Inverter, FR7, Protection Class IP21



Figure 5-6. ACCel500 Inverter, FR8, Protection Class IP00

5-1.3 CABLE INSTALLATION AND THE UL STANDARDS

To meet the UL (Underwriters Laboratories) regulations, a UL-approved copper cable with a minimum heat-resistance of +60/75°C must be used.

The tightening torques of the terminals are given below in Table 5-7.

TABLE 5-7. TERMINAL TIGHTENING TORQUES

Type	Frame	Tightening torque [lb-ft (Nm)]
ACD0003 - 0012 5	FR4	0.37 – 0.44 (0.5 to 0.6)
ACD0038 - 0061 5 ACD0004 - 0034 6	FR6	7.38 (10)
ACD0072 - 0105 5 ACD0041 - 0080 6	FR7	7.38 (10)
ACD0140 5 ACD0062 – 0100 6	FR8	14.75/6.64* (20/9)*

* Tightening torque of terminal connection to the isolative base.

5-1.4 CABLE AND MOTOR INSULATION CHECKS

1. Motor cable insulation checks.

Disconnect the motor cable from terminals U, V, and W of the inverter and from the motor. Measure the insulation resistance of the motor cable between each phase conductor as well as between each phase conductor and the protective ground conductor. The insulation resistance must be >1MΩ.

2. DC supply cable insulation checks.

Disconnect the DC supply cable from terminals B- and B+ of the inverter and from DC supply. Measure the insulation resistance between each conductor and ground. The insulation resistance must be >1MΩ.

3. Motor insulation checks

Disconnect the motor cable from the motor and open the bridging connections in the motor connection box. Measure the insulation resistance of each motor winding. The measurement voltage must equal at least the motor nominal voltage but not exceed 1,000 V. The insulation resistance must be >1MΩ.

5-2 CONTROL UNIT

The control unit of the inverter consists of the control board and option boards (see Figure 5-7 and Figure 5-20) connected to the five slot connectors (A to E) on the control board. The control board is connected to the power unit through a D connector (1).

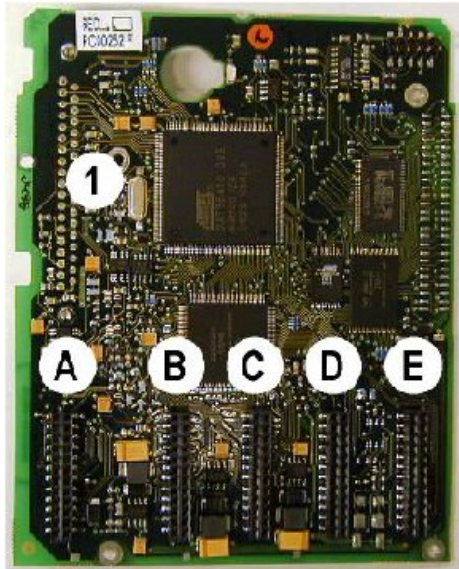

Figure 5-7. Control Board

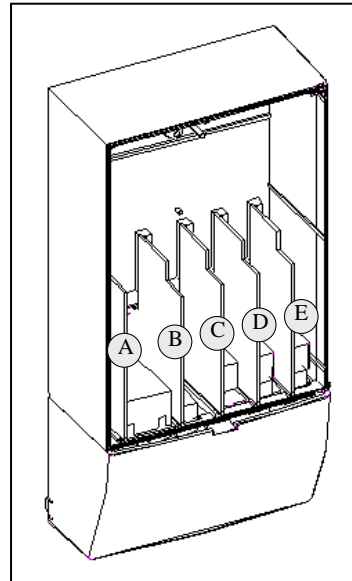
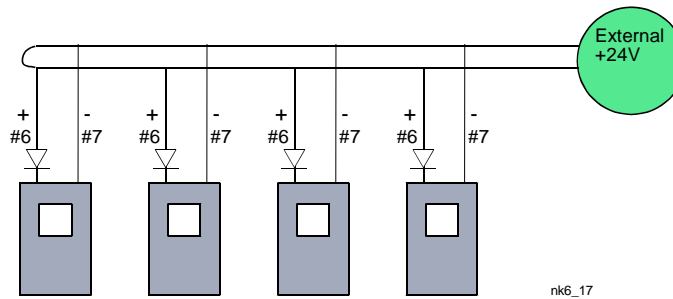

Figure 5-8. Basic and Option Board Connections on the Control Board

When the inverter is delivered from the factory, the control unit usually includes two basic boards (I/O board and relay board), which are normally installed in slots A and B. On the next pages you will find the arrangement of the control I/O and the relay terminals of the two basic boards, the general wiring diagram and the control signal descriptions. The I/O boards mounted at the factory are indicated in the type code. For more information on the option boards, see Accel500 Expander I/O and Adapter I/O Boards manual.

The control board can be powered externally (+24V) by connecting the external power source to bidirectional terminal #6 (see Table 5-9). This voltage is sufficient for parameter setting and for keeping the fieldbus active.

If the +24V input of several inverters are connected in parallel, we recommend to use a diode in terminal #6 to avoid the current to flow in opposite direction, which might damage the control board.



5-2.1 CONTROL CONNECTIONS

The basic control terminal signal descriptions for boards A1 and A2/A3 are shown in section 5-2.2.

The signal descriptions for all applications are presented in the ACCel500 Adjustable Frequency Drives Application Manual.

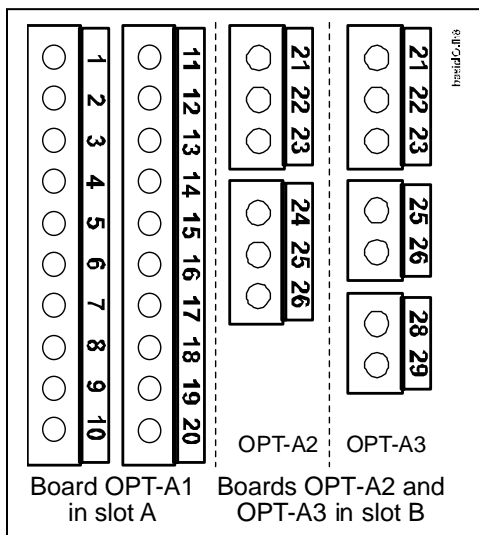

Figure 5-9. Basic Boards I/O Terminals

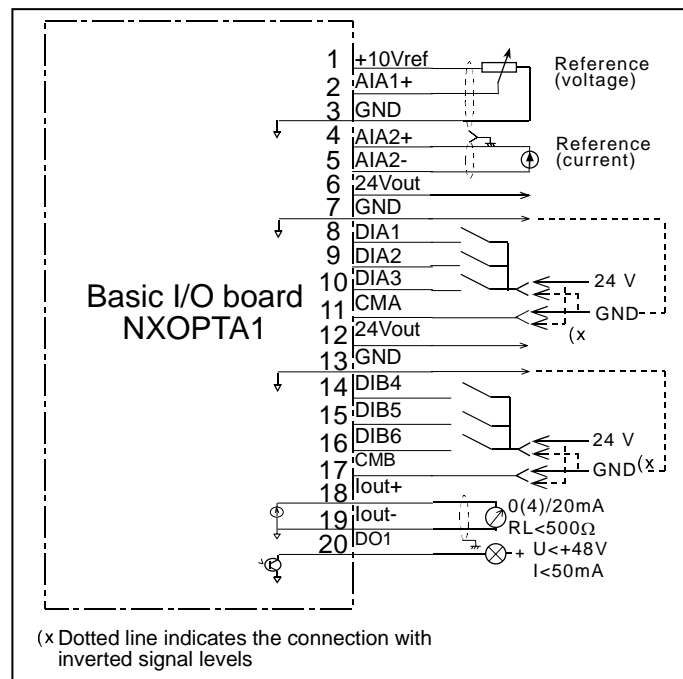

Figure 5-10. General Wiring Diagram – Basic I/O Board (OPTA1)

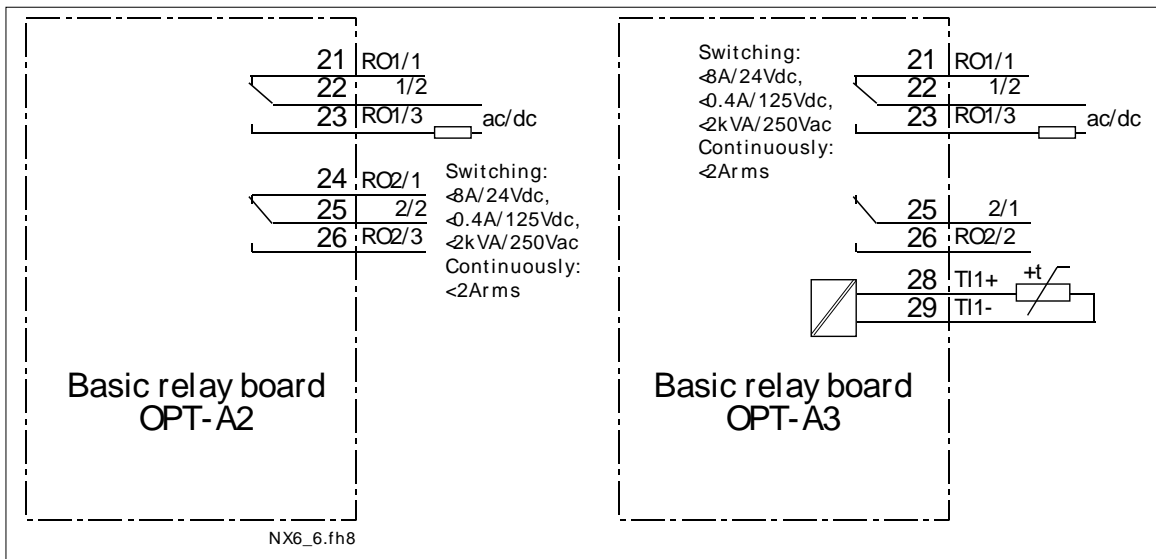

Figure 5-11. General Wiring Diagram - Basic Relay Boards (OPTA2/OPTA3)

5-2.1.1 Control Cables

The control cables shall be at least 0.5 mm² screened multicore cables (see Table 5-8). The maximum terminal wire size is 2.5 mm² for the relay terminals and 1.5 mm² for other terminals.

You can find the tightening torques of the option board terminals below.

TABLE 5-8. TERMINAL TIGHTENING TORQUES

Terminal screw	Tightening Torque	
	Nm	lb-in
Relay and thermistor terminals (screw M3)	0.5	4.5
Other terminals (screw M2.6)	0.2	1.8

5-2.1.2 Galvanic Isolation Barriers

The control connections are isolated from the mains potential and the GND terminals are permanently connected to ground. See below.

The digital inputs are galvanically isolated from the I/O ground. The relay outputs are additionally double-isolated from each other at 300 VAC (EN-50178).

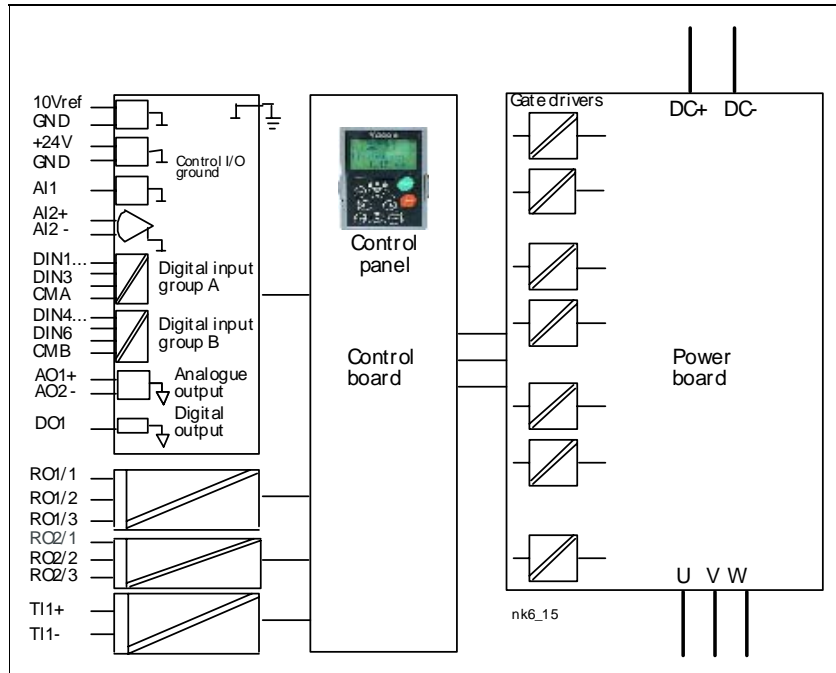

Figure 5-12. Galvanic Isolation Barriers

5-2.2 CONTROL TERMINAL SIGNALS

TABLE 5-9. CONTROL I/O TERMINAL SIGNALS ON BASIC I/O BOARD (OPTA1)

Terminal	Signal	Technical Information
1	+10 V _{ref}	Reference voltage Maximum current 10 mA
2	AI1+	Analog input, voltage or current Selection V or mA with jumper block X1 (see Figure 5-15): Default: 0– +10V (R _i = 200 kΩ) (-10V to +10V joystick control, selected with a jumper) 0– 20mA (R _i = 250 Ω)
3	GND/AI1–	Analog input common Differential input if not connected to ground; Allows ±20V differential mode voltage to GND
4	AI2+	Analog input, voltage or current Selection V or mA with jumper block X1 (see Figure 5-15): Default: 0– 20mA (R _i = 250 Ω) 0– +10V (R _i = 200 kΩ) (-10V to +10V joystick control, selected with a jumper)
5	GND/AI2–	Analog input common Differential input if not connected to ground; Allows ±20V differential mode voltage to GND
6	24 V _{out} (bidirectional)	24V auxiliary voltage ±15%; maximum current 250 mA all boards total; 150 mA from single board. Can also be used as external power backup for the control unit (and fieldbus).
7	GND	I/O ground Ground for reference and controls
8	DIN1	Digital input 1
9	DIN2	Digital input 2
10	DIN3	Digital input 3
11	CMA	Digital input common A for DIN1, DIN2 and DIN3. Must be connected to GND or 24V of I/O terminal or to external 24V or GND. Selection with jumper block X3 (see Figure 5-15):
12	24 V _{out} (bidirectional)	24V auxiliary voltage Same as terminal #6
13	GND	I/O ground Same as terminal #7
14	DIN4	Digital input 4
15	DIN5	Digital input 5
16	DIN6	Digital input 6
17	CMB	Digital input common B for DIN4, DIN5 and DIN6 Must be connected to GND or 24V of I/O terminal or to external 24V or GND. Selection with jumper block X3 (see Figure 5-15):
18	AO1+	Analog signal (+output)
19	AO1–	Analog output common Output signal range: Current 0(4)–20mA, R _L max. 500Ω or Voltage 0–10V, R _L >1kΩ Selection with jumper block X3 (see Figure 5-15):
20	DO1	Open collector output Maximum U _{in} = 48VDC Maximum current = 50 mA

TABLE 5-10. CONTROL I/O TERMINAL SIGNALS ON BASIC RELAY BOARD (OPTA2)

OPTA2				
21	RO1/1		Relay output 1	Switching capacity 24 VDC/8A 250 VAC/8A 125 VDC/0.4A Min. switching load 5 V/10mA
22	RO1/2			
23	RO1/3			
24	RO2/1		Relay output 2	Switching capacity 24 VDC/8A 250 VAC/8A 125 VDC/0.4A Min. switching load 5 V/10mA
25	RO2/2			
26	RO2/3			

TABLE 5-11. CONTROL I/O TERMINAL SIGNALS ON BASIC RELAY BOARD (OPTA3)

OPTA3				
21	RO1/1		Relay output 1	Switching capacity 24VDC/8A 250 VAC/8A 125 VDC/0.4A Min. switching load 5 V/10mA
22	RO1/2			
23	RO1/3			
25	RO2/1		Relay output 2	Switching capacity 24 VDC/8A 250 VAC/8A 125 VDC/0.4A Min. switching load 5 V/10mA
26	RO2/2			
28	TI1+		Thermistor input	
29	TI1-			

5-2.2.1 Digital Input Signal Inversions

The active signal level depends on which potential the common inputs CMA and CMB (terminals 11 and 17) are connected to. The alternatives are either +24V or ground (0 V). See Figure 5-13.

We recommend the use of positive logic in all control connections of the inverter. If negative logic is used, additional appropriate measures are needed to meet the safety regulation requirements.

The 24 volt control voltage and the ground for the digital inputs and the common inputs (CMA, CMB) can be either internal or external.

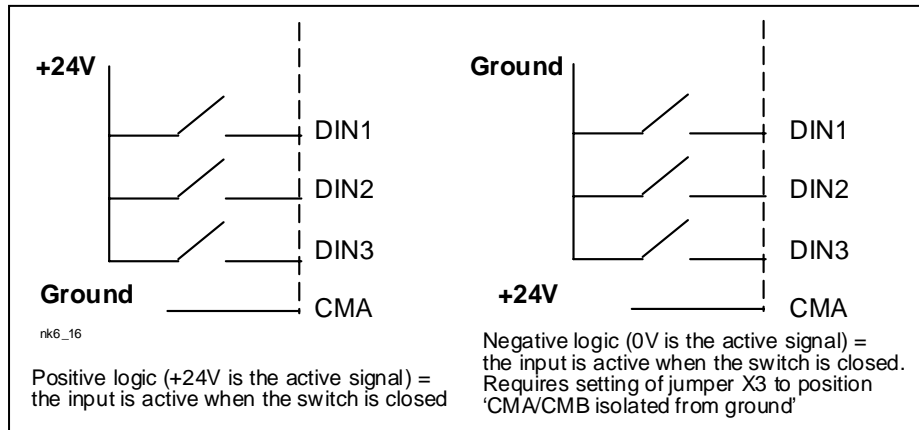

Figure 5-13. Positive/Negative Logic

5-2.2.2 Basic Board Jumper Selections (OPTA1)

The user can customize the functions of the inverter to better suit his needs by selecting certain positions for the jumpers on the OPTA1 board. The positions of the jumpers determine the signal type of analog and digital inputs.

On the A1 basic board, there are four jumper blocks (X1, X2, X3 and X6) each containing eight pins and two jumpers. The selection possibilities of the jumpers are shown in Figure 5-15.

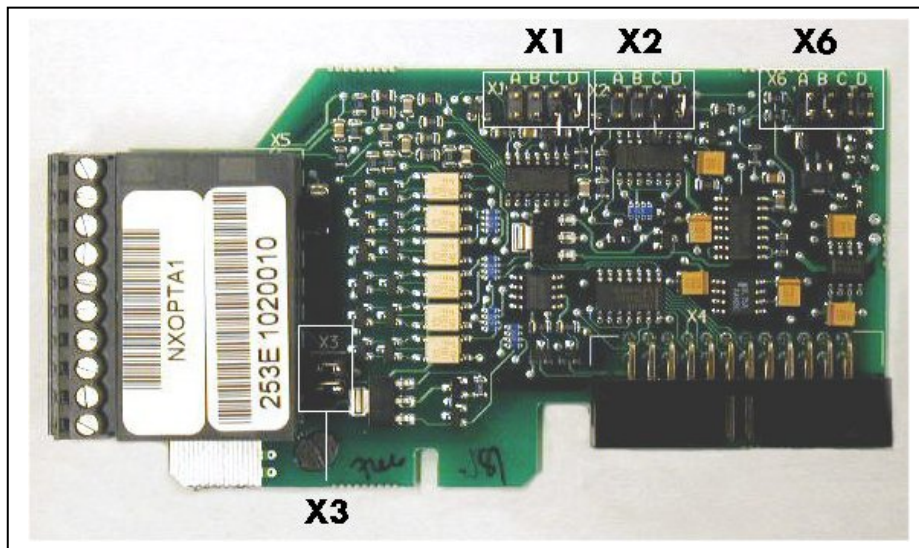

Figure 5-14. Jumper Blocks on OPTA1

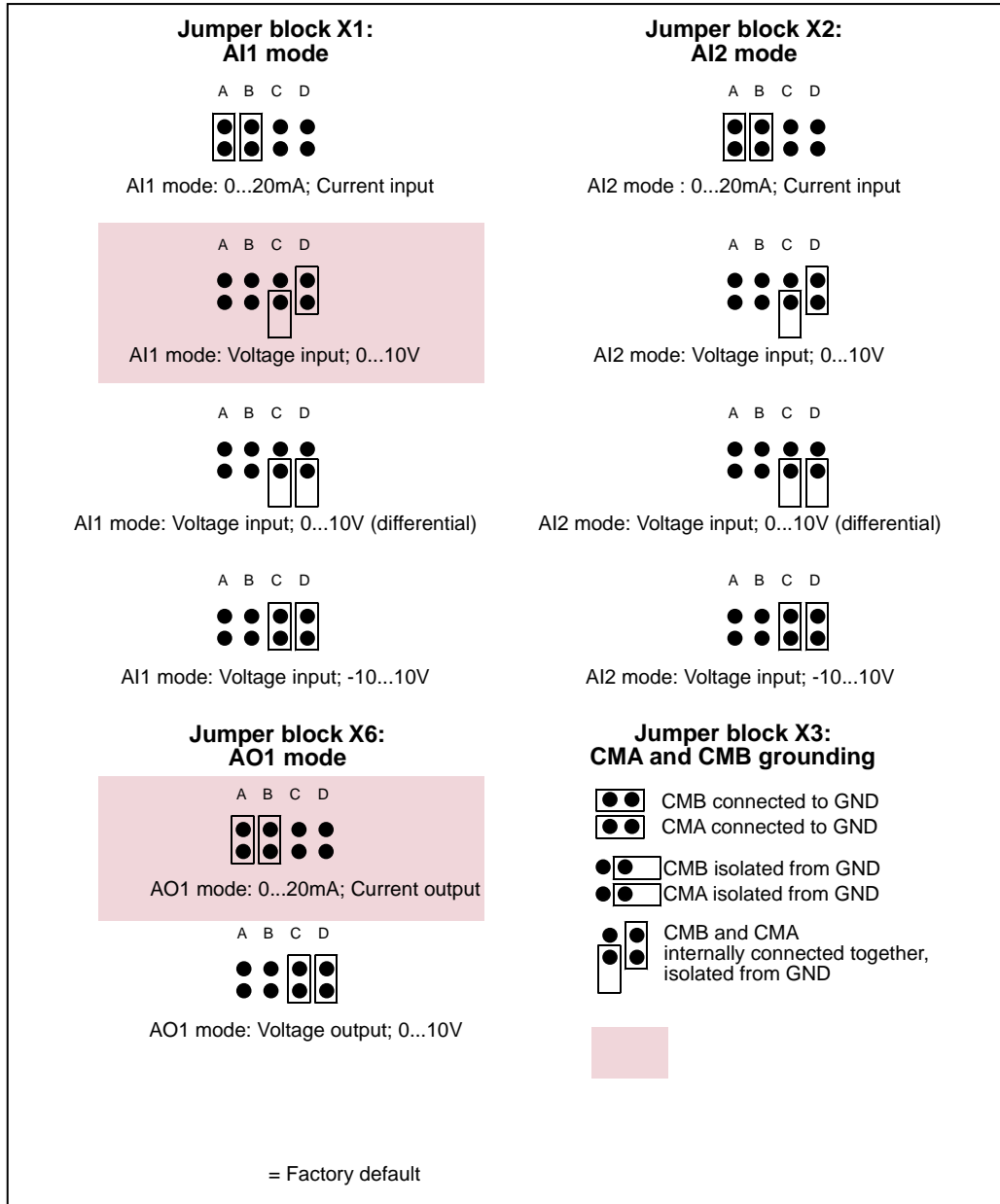

Figure 5-15. Jumper Selection for OPTA1

WARNING

Ensure that the jumper positions are correct. Running the motor with signal settings that differ from the jumper positions will not harm the inverter but may harm the motor.

If you change the AI/AO signal content, also remember to change the corresponding board parameter in menu M7.

SECTION VI

COMMISSIONING

6-1 SAFETY

Before commissioning, note the following directions and warnings:

- Internal components and circuit boards of the inverter (except for the galvanically isolated I/O terminals) are live when ACCel500 inverter is connected to mains potential. Coming into contact with this voltage is extremely dangerous and may cause death or severe injury.
- The motor terminals U, V, W and the DC link/brake resistor terminals +/- are live when ACCel500 inverter is connected to DC supply, even if the motor is not running.
- The control I/O terminals are isolated from the mains potential. However, the relay outputs and other I/O terminals may have a dangerous control voltage present even when the ACCel500 inverter is disconnected from the DC supply.
- Do not make any connections when the inverter is connected to the DC supply.
- After having disconnected the inverter, wait until the fan stops and the indicators on the keypad go out (if no keypad is attached see the indicator through the keypad base). Wait 5 more minutes before doing any work on ACCel500 inverter connections. Do not open the cover before the time has expired.
- Before connecting the inverter to DC supply make sure that the ACCel500 inverter front cover is closed.
- When running, the side of inverter FR8 is burning hot. Do not touch it with bare hands.
- When running, the back of inverter FR6 is burning hot. Therefore it **MUST NOT** be mounted onto a surface which is not fireproof.

6-2 COMMISSIONING THE INVERTER

1. Read carefully the safety instructions in Chapter 1 and above and follow them.
2. After the installation, make sure that:
 - both the inverter and the motor are grounded
 - the DC supply and motor cables comply with the requirements given in section 5-1.1.

- the control cables are located as far as possible from the power cables the shields of the shielded cables are connected to protective earth . The wires may not touch the electrical components of the inverter.
 - the common inputs of digital input groups are connected to +24V or ground of the I/O terminal or the external supply.
3. Check the quality and quantity of cooling air (See section 4-2 and Table 4-6).
 4. Check the inside of the inverter for condensation.
 5. Check that all Start/Stop switches connected to the I/O terminals are in Stop position.
 6. Connect the inverter to DC supply.
 7. Set the parameters of group 1 according to the requirements of your application. At least the following parameters should be set:
 - motor nominal voltage
 - motor nominal frequency
 - motor nominal speed
 - motor nominal current

You will find the values needed for the parameters on the motor rating plate.

8. Run the start-up tests without the motor being connected to the process. If this is not possible, make sure that running each test is safe prior to running it. Inform your co-workers of the tests.
 - a. Switch off the DC supply voltage and wait until the drive has stopped as advised in section 6-1.
 - b. Connect the motor cable to the motor and to the motor cable terminals of the inverter.
 - c. Make sure that all Start/Stop switches are in Stop positions.
 - d. Switch the supply voltage ON
 - e. Repeat test 8A or 8B.
9. Connect the motor to the process (if the start-up test was run without the motor being connected).
 - a. Before running the tests, make sure that this can be done safely.
 - b. Inform your co-workers of the tests.
 - c. Repeat test 8A or 8B.